

Youth Four Stroke ATV User Manual



www.bobcatsmotorsports.com

Sales: 916-913-1229 Fax: 916-913-1349
sales@bobcatsmotorsports.com

Parts & Tech Support: 916-333-3810
support@bobcatsmotorsports.com

Notes:

- 1) The exhaust pipe on the right foot side could be hot after a long time riding, be careful.
- 2) While use remote start, the ATV may start to move after start up, if the idle speed is not set properly, be careful.
- 3) This manual is prepared based on the information provided by the manufacturer, if any content in this manual is not appropriate, please consult a qualified mechanic or auto electrician.

1.0 FEATURES OF THIS MODEL

- Proven LONCIN engine.
- Four stroke engine for smooth power and reliability.
- Easy electric start.
- Maximum speed can be restricted for beginners.
- The ATV is equipped with an alarm system. The engine can be shut down remotely for adult supervision.
- To ensure a child's safety, a parent can walk behind the ATV, holding a cord attached to the cutout at the back of the quad. A quick tug on the cord will cutout the engine
- The ATV has a kill switch on the handle bar.
- The size and weight make this model easy for a child to handle and easy to load into a family car.
- The knobby tires, good suspensions and the strong engine will ensure that riding this little bike be a lot of fun.
- The low cost, sturdy design and nice look make this model an instant hit with children.
- The size of the 110cc engine will always excite your rider as they progress from a beginner to an expert, from tiny to confident youth.
- One brake stops this little quad - no confusion for the little ones.

2.0 SAFETY PRECAUTIONS

Safety is extremely important when allowing young children to ride a motor bike. Children of the same age can have different levels of skill and coordination, so only a parent can understand their child's capabilities. If a parent decides to allow a child to ride a motorized vehicle, it is essential that they realize that the child's safety rests entirely on their hands. The child must NEVER be unsupervised.

The quad's speed must be set to match the child's capability at all times. The parent is the only person responsible for the child's safety. By allowing the child to ride a quad, the parent accepts that this is his sole responsibility and risk.

The governor on the quad should be set to allow the child to travel only at a walking pace while learning to ride. The area in which the child is allowed to ride must be free of obstacles that could be a danger to the child and free of people and animals that could be injured. As the child's capability increases, the quad's speed can gradually be increased but always only to a safe level.

Please read and apply all the safety information in this manual. Remember: you are responsible for your own safety and the safety of those in your care. Adventure imports cannot be held liable for accidents, no matter what the cause. You are responsible for checking your vehicle thoroughly for faults and for riding safely.

Operating any motorized vehicle carries an element of risk. By choosing to ride this vehicle, you have accepted this risk. Adventure imports is not responsible for negligence, speeding, component failure, inexperience or other unforeseen circumstances that can cause injury or death.

To help you ride and operate the quad safely, here is some advice to increase your safety awareness.

- Ride under the instruction of a competent teacher until you are an experienced rider.
- These vehicles are designed and manufactured for off-road use only. It is illegal and unsafe to use this machine on any public street, road or highway, paved, tarred or cement surfaces
- Check local riding laws and regulations before operating this machine.
- Check local environmental laws.
- Riding an ATV is serious; it can be hazardous to operate. A collision or rollover can occur quickly, often with serious consequences. Even in routine maneuvers such as turning, riding over obstacles and on sloping ground or across water, mud or loose surfaces, the quad handles differently from other vehicles.
- Never carry passengers, as this alters the handling characteristics dangerously.
- Never exceed the recommended load capacity. Overloading or improper loading can cause mechanical failure, loss of control and unnecessary danger.
- Always keep both hands and both feet securely on the ATV.
- Never attempt stunts, jumps, wheelies or other tricks.
- Never ride faster than your skill or conditions permit.
- Never ride when tired or after consuming alcohol or drugs or while experiencing any dangerous medical condition.
- Inspect your ATV each time you use it to make sure there are no mechanical faults or problems with tires, brakes or controls. Your ATV must be in safe operating condition at all times, with sufficient oil, gas, and brake fluid and tire pressure.
- Never use your ATV in flowing water or in water deeper than 5 inches.
- Always use the recommended tire pressure to reduce the risk of tire failure.
- Always turn the engine OFF when refueling.
- Don't run the engine in an enclosed area -THIS CAN BE FATAL.
- Always wear an approved helmet that fits snugly as well as eye protection, gloves, a long sleeved jacket and long pants.
- Engine oil from a recently run motor can be very hot. When draining oil for an oil change, be careful.
- Be sure to replace fuses with ONLY the correct ones; using an incorrect fuse can cause a fire.
- Never put your feet on the ground when the vehicle is starting off or moving.
- It is your responsibility to ensure that the ATV is properly and safely ridden and maintained.

- People should not operate an ATV beyond their physical or mental limits or capabilities.
- While you are learning to ride, use an ATV only on level, open ground away from people.
- If you allow an untrained person to use the ATV, you are endangering his/her life and the lives of others.
- Check that the ATV throttle and throttle cables are free and working. A jammed throttle can cause an expensive and injurious accident.
- In some other countries ATVs with 110cc or smaller engines cannot be driven by those aged 6 and under. Recommend that riders under age 16 should ride only with adult supervision and only after training.
- All riders should take a course of safety instruction.
- Never use gasoline (petrol) to clean the ATV. A slight spark could cause a fatal explosion. Keep a fire extinguisher nearby when working on the ATV.
- Excessive "play" or slippage on a drive chain can cause the chain to break which could, in turn, cause a serious accident. "Grabbing," shuddering or lack of braking ability could mean there is a serious brake problem. This must be fixed before riding or serious injury could result.
- The high-tension wire from the CDI unit to the sparkplug generates extremely high voltage and can cause a serious or fatal shock if touched with the power on.
- Don't touch any part of the engine, exhaust pipe until it has cooled down.
- Don't siphon toxic liquids such as fuel or brake fluid by mouth or allow them to remain on your skin.
- Wipe up IMMEDIATELY any oil or grease that could cause you to slip or lose control of the ATV.
- Don't allow animals or children to be around an unattended ATV.
- Keep loose clothing and long hair well out of the way of moving parts.
- Remember: MANY PEOPLE HAVE LOST FINGERS OR LIMBS that were pulled into moving parts, especially chains. DO NOT WORK ON THE ATV WITH THE ENGINE RUNNING.
- If, despite all these precautions, you are injured, seek medical attention immediately.

3.0 TEACHING TECHNIQUES

Your student's safety depends on your commitment to take the time necessary to fully educate him/her on the proper operation of the ATV. Remember that proper instruction before your student begins to ride is just as important as proper instruction and supervision while riding.

Following is a step-by-step guide to help make your student's first use of the ATV safe and enjoyable. Before you go through the steps, however, be sure you have reviewed the vehicle features. Be sure to take breaks as the student becomes tired or his/her attention starts to wander. Full attention at all times is needed to safely operate any motorized vehicle.

STEP 1: PROPER CLOTHING & PROTECTIVE GEAR

The first step to safe riding is proper protection of the rider. Your student should always wear a helmet, eye protection, gloves, long pants, a long-sleeved shirt or jacket and boots. Make sure your student is not wearing any loose-fitting clothes. Loose belts, scarves, etc can get caught in moving parts and cause personal injury. Even in hot weather, make sure the student wears long pants and a long-sleeved shirt. These not only protect against abrasive injuries but also help reduce fatigue which comes from loss of body heat caused by exposure to the wind.

STEP 2: FAMILIARIZATION WITH THE VEHICLE

Your student should become completely familiar with the names and functions of all controls. Demonstrate operation of the controls if necessary. Ask the student to do such things as "Apply the brakes. Turn off the engine," etc. Practice this exercise until the student can operate all of the controls without hesitation.

STEP 3: STARTING OFF AND STOPPING

To help your student develop confidence, she/he should PRACTICE FIRST WITH THE ENGINE OFF, as follows:

- Have student sit on ATV.
- Instruct student to keep his/her eyes straight ahead while you slowly push the vehicle from behind. This will give the student the "feel" of riding a moving vehicle.
- As you push the ATV, instruct your student to steer straight ahead and perform operations such as stopping the vehicle. Watch your student closely to make sure she/he is operating the controls correctly and without looking at them.
- As you approach the end of the practice area, tell your student to stop the vehicle.
- You should drag the rear end of the ATV around so you can push it straight ahead in the opposite direction.
- Practice with the engine OFF until your student gets the "feel" of using the brakes and can stop the vehicle and turn OFF the engine switch without hesitation and without looking at the controls.

STEP 4: ADJUST THE SPEED LIMITER TO SLOW

Next, start the ATV's engine and have the student practice starting off, riding in a straight line and stopping with the vehicle under power. Walk alongside the ATV and hold the engine cutout switch cord. Make sure your student:

- Opens the throttle gently when starting off.
- Releases the throttle and applies the brakes in sequence when stopping.
- Becomes aware of the distance it takes the vehicle to stop when the engine switch is turned OFF while the vehicle is moving.
- As you approach the end of the practice session, you should again tell the rider to stop the vehicle and get off so you can turn it around for him/her. Practice this exercise until your student can start off, accelerate, cruise and stop correctly and confidently.

STEP 5: TURNING

After your student has learned to ride the ATV in a straight line and can stop it at will, you should teach the student how to turn the vehicle. Explain the proper body movements for turning and let the student PRACTICE FIRST WITH THE ENGINE OFF as you push the vehicle from behind.

When turning, watch to make sure your student:

- Shifts his/her weight slightly forward and supports his/her weight on the outer footrest.
- Leans his/her upper body into the direction of the turn, pressing down with the opposite leg.

When the rider is able to properly turn the ATV in both directions with the engine OFF, she/he should practice turning with the vehicle under power. Again, make sure that the throttle limiter is adjusted to provide a low maximum speed capability. Watch closely to make sure the rider is using the proper technique. The rider should practice turning until s/he can do so correctly and confidently.

STEP 6: PUTTING IT ALL TOGETHER

When your student has mastered the basic riding maneuvers in the previously listed steps, she/he should practice them all together. Instruct the student to perform various maneuvers such as turning right, turning left, stopping, etc. Vary the order of these maneuvers so the student will not anticipate what s/he will be asked to do next. Practice this exercise until you are confident that the rider has mastered all the basic maneuvers. Using this procedure will help the first-time rider learn the most basic riding techniques. To become a skilled rider, your student will need a great deal of practice and continuing instruction in addition to completing these introductory steps. After all the riding techniques have been mastered, you can adjust the throttle limiter to provide higher speed capabilities in keeping with the rider's skill and experience.

4.0 SETUP AND ADJUSTMENT

Uncrating the ATV, assemble the handlebar, the front bumper and the rear cargo bar. The battery is located underneath the seat. The seat can be removed by pull back the seat lever, which can be accessed from the back of the ATV. Connect the red wire to the positive terminal of the battery, and the black wire to the negative terminal of the battery. You may hear a beep sound once the battery is connected.

CHECK THE ATV BEFORE STARTING ENGINE

The manufacturer has done a basic driving test before packing. However, we recommend you do the following check before you start the engine.

- Check the battery voltage, it should normally be 12V. Charging the battery if the battery voltage is too low.
- Check the brake and fluid, and make sure the brake control is smooth and adjusted.
- Check for smooth rotation of throttle in all steering position. No break, crack, or deformation is seen for throttle grip and the connecting parts.
- Check that the fuel line has been plugged into the carburetor, and there is no crimp with the fuel line.
- Check tire pressure.
- Check that the chain has a proper slack.
- Check lock nuts for the wheels and steering rods, tighten them if needed.
- Check the safety pin for the lock nuts, crimp and secure them if needed.
- Check the steering of the ATV, align the wheels if needed.
- Check the engine oil, add oil to a proper level if needed.
- Check for any loose parts.

STARTING THE ATV FOR THE FIRST TIME

Add a small amount (half liter or so) of petrol in the gas tank, and check for any fuel leaks. Don't try to start the engine if you should see any fuel leaking.

Add fuel to a proper level. Switch the ignition key to the "on" position, and flick the kill switch away from you. Hold the brake lever, the two rear lights will light up. Now press the start button to start the engine. Refer to picture 1.



The choke is located on the right side of the ATV if you are sitting on it. It is under the plastic cover. It may not be convenient to access the choke, and you might have to remove the seat. Refer to picture 2, the choke is closed when the choke lever is pulled up, and the choke is open when the choke lever is pressed down.

The choke shall be used if you have trouble to start the ATV. When the engine is cold: close the choke, and press the start button to start the engine. Immediately after the engine starts, press the choke lever halfway down and allow warm up the engine for a few minutes, then push the choke down to a fully open position. Let the engine run until the engine sufficiently warms up before a ride.

When the engine is warm: Open the throttle 1/8 to 1 /4, press the starter button to start the engine. Operation of the choke is usually not necessary when starting warm engine. The choke should be at open position (push down fully).

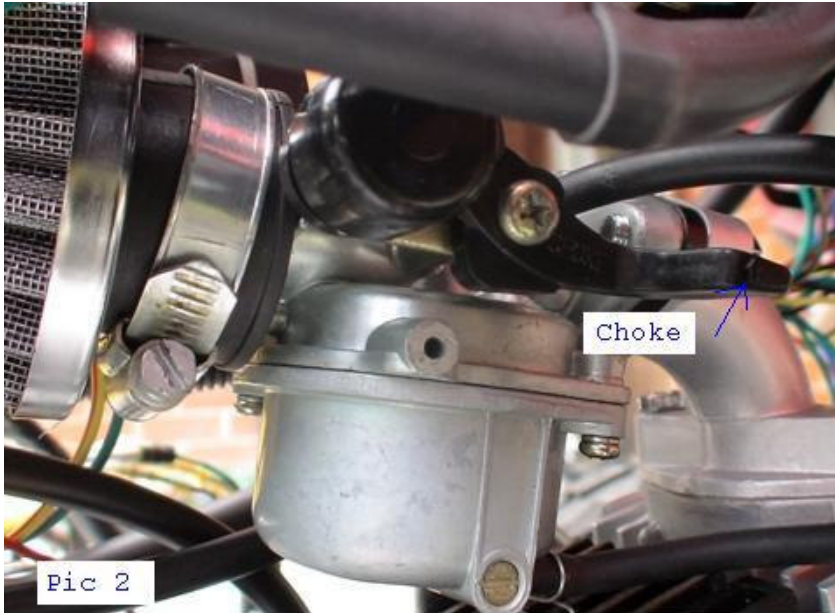

TURN OFF THE ENGINE

Switch the ignition key to "off "position shuts down the engine. Or flick the kill switch towards you shuts down the engine.

ADJUST IDLE SCREW

Once the engine is running it should be warmed up for five to ten minutes, then adjustment of idle speed can be carried out. Refer to picture 3 for idle screw. Leave the throttle off, and turn the idle screw in or out so that the engine runs at a proper RPM. With a proper adjustment of the idle screw the engine shall stay running smoothly after start up. Turning the idle screw clockwise will richen the fuel and increase the idle speed. Caution: the vehicle may start to move when turn the idle screw. Hold the brake while carrying out the adjustment of idle screw.

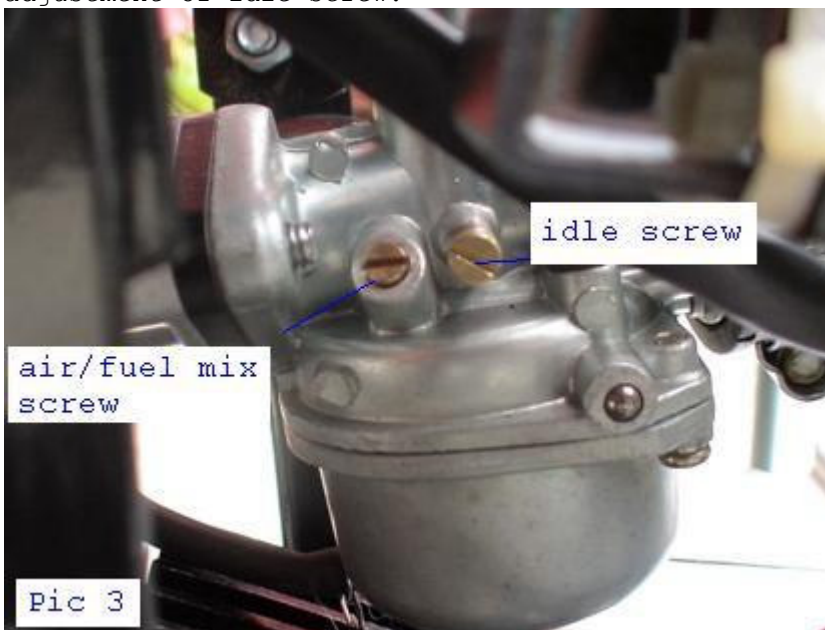

ADJUST AIR/FUEL MIX SCREW

The mix screw has been properly adjusted at factory, and normally it does not need further adjustment. However, if you are operating the ATV a high altitude then you need lean out the air /fuel mixture to help keep the engine running at peak performance.

If you have a difficulty to start the engine in cold weather, you may also need to adjust the mix screw to richen the mixture until engine starts easily in the cold, you may also need to increase the idle speed in the cold weather. Refer to Picture 3 for air/fuel mix screw.

You may have to balance the air/fuel mix screw and the idle screw. You know they have been adjusted properly when there is only a slight hesitation when the engine accelerates to a high RPM.

The spark plug (picture 4) will let you know if the mixture is running lean or rich by the color on the tip; the proper color for the tip of the plug is a beer bottle brown. If the engine is running lean the plug will be a white or light gray in color. Do not run the engine with it running lean severe engine damage may result, if it is running rich it will be black with carbon and maybe wet with fuel. It is better to run the mixture on the richer side than the leaner side. A new plug will be needed each time the spark plug is found in any one of these conditions, and an adjustment is needed. The only way to tell the condition is with a new plug each time, the plug will still be useable just not good for this test.

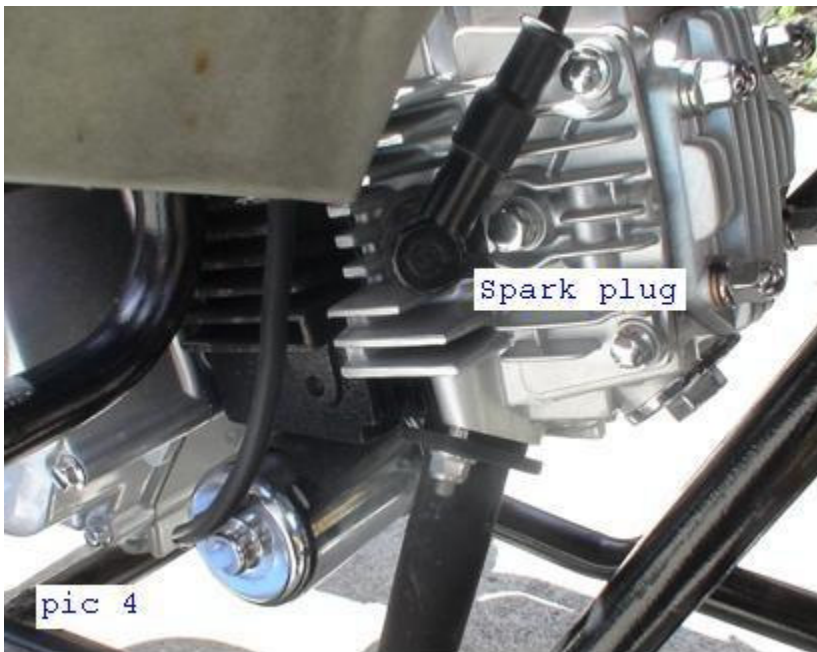

THROTTLE CABLE ADJUSTMENT

The adjustment is to ensure that the throttle cable is pulling full throttle and to set free play in the thumb throttle lever. There is a turn buckle assembly, refer to picture 5. The thumb throttle should have 2-4mm of free play before it tightens up and starts pull the slide of carburetor up. Loosen the lock nut and turn the adjuster until the required free play achieved.

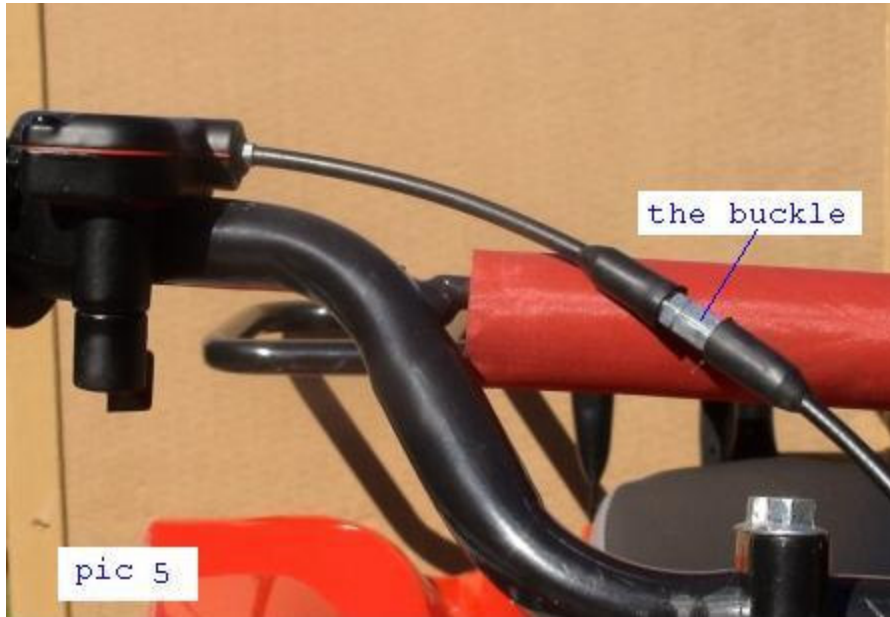

THROTTLE SPEED LIMIT SCREW

Check the throttle limit screw on the right handlebar and make sure it is not limiting full throttle. If the child is young and inexperienced, loosen the jamb nut and turn the screw clockwise all the way to limit top speed, tighten the jamb nut while hold the screw with a screw driver. Refer to picture 6.



BRAKE ADJUSTMENT

The hydraulic brake system has normally been adjusted in the factory. The brake lever should not have more than 20mm travel before applying the brake. If there is too much travel distance, do the adjustment as followed: remove the rubber cap, and squeeze the brake lever a few times, until you feel braking resistance when you pull the brake lever. You may need to add brake fluid if above adjustment is not successful. In the case the brake is too tight and drags the disk, do the adjustment as followed: disconnect the hydraulic line at the brake end, use screw driver to push the brake pad, and this give more clearance between the brake pad and the disk. Refer to picture 8.

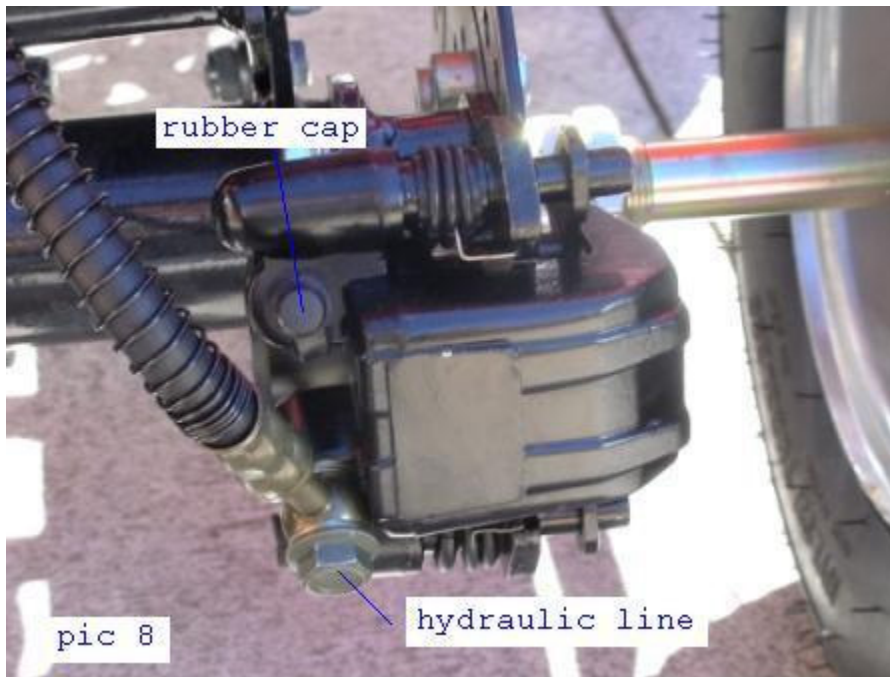

CHAIN ADJUSTMENT

The chain should not too tight or too loose, the proper slack should be around half an inch (12mm). There are two studs that will take up the slack by rotating the rear axle housing. First loosen the axle housing bolts; then adjust two nuts. Refer to pictures 8 and 9.

After the ATV has been used the chain will stretch as the ATV gets broken in and the chain will need to be adjusted from time to time. The chain should be inspected and lubricated by an adult every time the ATV is going to be rode. If the chain adjuster can not be turned in so all the slack is removed, then the chain should be replaced.



CLUTCH ADJUSTMENT

With the centrifugal clutch it will need to be adjusted as it wears. There is an external adjustment screw that will either put more or less tension on the clutch disk. By holding the stud with a screw driver and loosening the jamb nut. Slowly turn the stud counter-clockwise until there is resistance is felt. Then turn the stud 1/8 turn clockwise. Tighten the locknut. Turning the adjusting stud clockwise will increase the free play (more slippage), and counter-clockwise will decrease the clutch free play (less slippage).

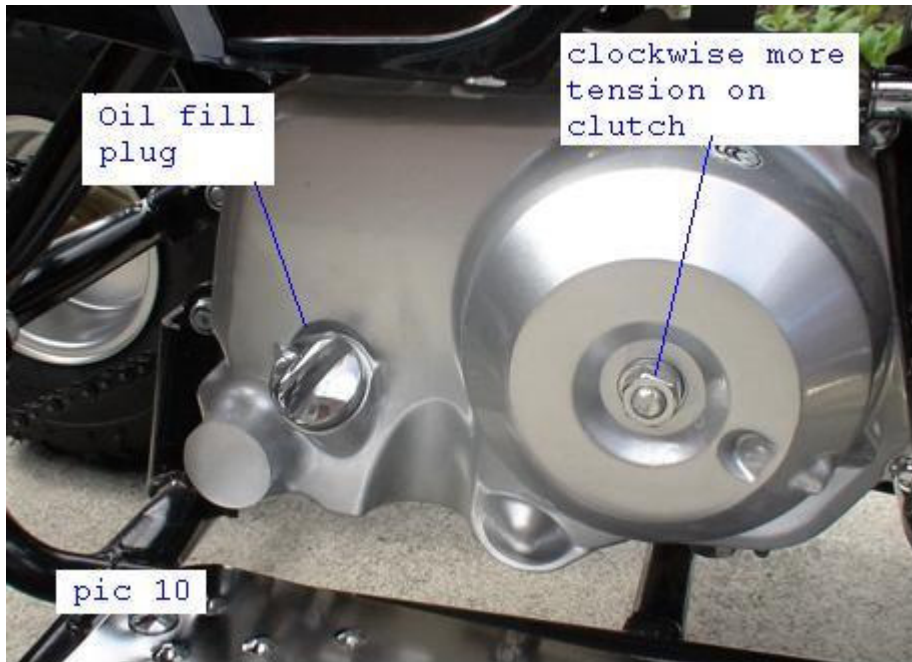

VALVE CLEARANCE CHECK

After the first 10-20 hours of riding the ATV, the valve clearance should be checked, as during this period of time the most wear occurs. Check the clearance for intake valve and the exhaust valve. The gap should be adjusted to 0.03-0.05mm, according to the engine manufacturer. Ask a qualified mechanic for help if you can not carry out these checks.

RUNNING-IN FOR A NEW ENGINE

The table shows the maximum speed in running-in period.

Initial 160km	less than 25km/h
Up to 800km	less than 30km/h
Up to 1600km	less than 35km/h

The engine speed should be varied and not held at a constant speed. This allows the mechanic parts to be "loaded" and "unloaded", and aids the matching process of the brand new engine. Operating the engine at constant low speed can cause parts to graze and not seat in. Allow the engine to accelerate freely provided that the recommended maximum limit is not exceeded. Do not, however, use full throttle for the first 1600km.

Allow sufficient idling time after engine startup before applying the load and revving the engine. This allows time for the lubricating to reach all critical engine parts.

The first 1000km service is the most important for your vehicle. During the running-in, all engine components will have worn in and seated in. At this time the dirty engine oil should be replaced and adjustments should be made.

FUEL AND OIL

Petrol: unleaded petrol,

Engine oil: your new ATV already has oil added, but we recommend that you drain the oil prior to your first use and add high quality SAE10w30 or SAE10w40 engine oil. You should check the oil level every time before starting engine. You should drain all oil at least once every 3 months.

After each time the ATV is used

Clean the ATV

Make sure the key is in off position

ALARM AND REMOTE CONTROL

The ATV is equipped with an alarm system. Refer to the follows for functions of key on the remote. There is a control box underneath the seat. The control electronics may become faulty due to water ingress, vibration, and excessive heat. If you relay on the remote to stop the ATV for supervising the young rider, please make sure the control system works as expected. The alarm system can be bypassed, and the ATV can still be operated without the control box. Note that with the alarm unplugged, the ignition key can not turn off engine, and you have to use the kill switch to shut down the engine.



There are 4 press buttons in each remote, as shown in the picture 11 above. These 4 press buttons are referred to LOCK, UNLOCK, STARTER, and SEARCH buttons for description of operation followed.

- 1) After the ATV stops and the ignition key being removed from the ATV, press the LOCK button, the beeper of the alarm system will sound "Bee" once, and the alarm system will be active within 3

seconds, i.e. the ATV is armed within 3 seconds. When the ATV is armed and the ATV is being pushed, the beeper will sound "Bee" 4 times; the beeper will sound continuously if the ATV is being pushed again within 5 seconds.

- 2) When the alarm system is active and the beeper is beeping; press the LOCK button will stop beeping. The alarm system remains active, however.
- 3) Press UNLOCK button, the beeper will sound "Bee" twice, and the alarm system will be inactive, i.e. the ATV is disarmed.
- 4) Remotely starting ATV, press STARTER button **twice**, the engine will be started, regardless the position of ignition key and brake. Note that the ATV may run after remoter starting if the idle speed is adjusted too high, as the remote starting does not need to hold the brake.
- 5) Remotely stopping ATV, press UNLOCK button will stop engine
- 6) Press SEARCH button, the beeper will sound "Bee" 5 times, which will tell you where the ATV is.

Note that the remote is dedicated for the alarm system installed with your ATV, and it shall not trigger other vehicles or other electronic devices nearby. However, we recommend the users check this if there are multiple ATVs of same model in the same field.

5.0 STORING YOUR ATV

If the ATV is going to be stored for more than 60 days then there are some preventive things to guard against deterioration. After a good cleaning; the fuel tank, fuel line and carburetor float bowl need to be drained of all fuel. Remove the spark plug, pour about one teaspoon of SAE 10W30 motor oil in the spark plug hole and reinstall the spark plug. Turn the engine over several times slowly by hand not with the starter with out the plug wire hooked up, and this will coat the cylinder wall with oil to prevent rust and pitting. Block up the frame to raise all wheels off the ground with an approved jack stand or solid blocks and keep the wheels from flat spotting. Tie a plastic bag over the exhaust pipe with a rubber band to prevent moisture from entering. If the ATV is going to be stored in a humid or sea air atmosphere, coat all exposed metal surfaces with a light oil film. Do not apply oil to any rubber parts or the seat cover, use an approved vinyl upholstery cleaner to keep the seat cover pliable and glossy. Remove the battery and apply a full charge. Store the battery in a dry place and recharge it once a month. Do not store the battery in an excessively warm or cold place. Make any necessary repairs before storing the machine this will be less trouble for when the ATV will be used again.

6.0 WIRING DIAGRAM

